

ROYAL®

Cash Drawer
MB-30

**USER
MANUAL**

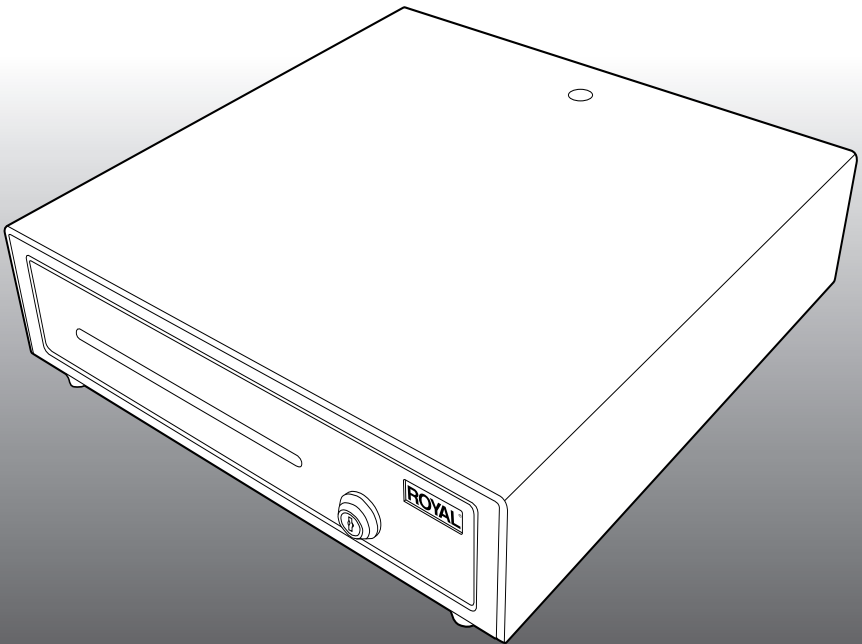

Please contact the
ROYAL CONSUMER PRODUCT SUPPORT HOTLINE
for operational assistance and problem resolution. Call toll-free.

Customer Service:

1-800-272-6229 (USA)

52-559-138-3300 (in Mexico)

Monday through Friday during normal business hours.

You can also e-mail Royal at: hotline@royal.com

To Order Supplies:

1-888-261-4555

INDEX

\\ INTRODUCTION	2
Unpacking	2
\\ INSTALLATION	3
Key lock operation	3
\\ MAIN FEATURES	4
\\ TECHNICAL SPECIFICATIONS	4
\\ USB TRIGGER	5

INTRODUCTION

The **MB-30 USB Cash Drawer** has 5-bill slots that are sized to accommodate either US, Canadian or Mexican paper currency. It also has a removable coin tray. The coin tray is preset with 8-coin slots.

The coin separators, creating the walls between each coin slot, are removable and can be re-positioned in another groove to change the size of each coin slot. Seven separators (only six separators are removable) are already installed in the coin tray to create 8-slots. To remove a separator already installed in the coin tray, lift out the removable coin tray from the cash drawer. While squeezing the bottom of the plastic separator where it inserts into the groove opening at the bottom of the coin tray, turn the coin tray upside-down and use a flat-head screwdriver from the opposite side to gently push the plastic locking tab out of the groove. Be careful not to break the plastic. To install a separator into the coin tray, line up the separator in a groove with the curved side of the separator facing down and into the coin tray matching the shape of the coin tray. Be sure the separator is in only one groove and push it all the way down into the coin tray until the locking tab clicks into position.

Unpacking

After unpacking the unit, please check that all the necessary accessories are included in the package.

- 1x Cash Drawer, Pre-assembled
- 2x Keys
- 4x Bill Dispenser Dividers
- 6x Coin Dispenser Dividers
- 5x Metal Bill Clippers
- 1x User Manual
- 1x USB Trigger

INSTALLATION

The cash drawer has been pre-assembled to make the installation as simple as possible. Connect the drawer to the POS printer. Whenever the POS application software sends a drawer open command to the POS printer, the printer will output a 12 to 24-volt electronic pulse to open the drawer.

1. Remove the cash drawer from the packing, then remove the keys and interface cable from the plastic bag.
2. Connect the interface cable to the POS printer.
3. Insert the bill dispenser divider and bill clipper to the cash tray.

You can connect your cash drawer directly to a POS or to a computer. You can use an RJ11 or USB interface, thanks to the USB trigger (please read more about the USB trigger at the end of this manual).

Key lock operation

The cash drawer has a **three-position key lock** (Figure1) and the fully counter clockwise lock position offers maximum security.

- The cash drawer cannot be opened by a printer signal or an individual when the lock is in the full clockwise position.
- With the lock in the center position, the drawer will open when an electronic pulse is received from the POS printer.
- The cash drawer is manually opened when the lock is in the counter clockwise position.

Figure 1

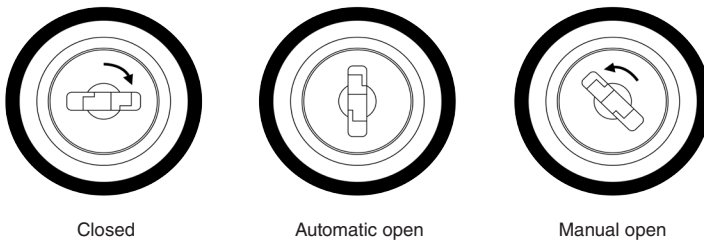

The cash drawer can be opened manually by using the hidden emergency lever underneath the register, towards the back of the cash box. This hidden emergency lever will not work when the lock is in the close position (see Figure 1 above).

WARNING: The cash drawer cannot be opened when it is locked using the cash drawer key. Do NOT lose these keys.

MAIN FEATURES

- Industrial grade materials
- Self-adjustable bill compartments
- Small foot-print
- Drawer opens from any POS printer drive circuit which has an RJ interface
- Three-position lock with unique key
- Slot for non-cash or large amount of bills
- Contemporary style
- Accurate mechanical parts with a tight tolerance to assure wobble-free drawer movement
- Fully compatible with other brands
- Ready for OLE POS (OPOS) OCX driver

TECHNICAL SPECIFICATIONS

MECHANICAL	
Overall Dimensions (mm)	410(w) x 415(d) x 100(h)
Overall Dimensions (inch)	16 ⁹ / ₆₄ (w) x 16 ¹¹ / ₃₂ (d) x 1 ⁵ / ₁₆ (h)
Mass (Approx.)	6.4Kg
ELECTRICAL (Input to Solenoid)	
Pulse Amplitude	24 VDC
Pulse Width	100-200 millisecond
Pulse Duty Cycle	10% maximum
Maximum Input Voltage	26.5 VDC
Current consumption	1A@12VDC
Activation current	0.9 A maximum
INTERFACE CABLE	
Pin1 (White)	Not connected
Pin2 (Black)	Solenoid-
Pin3 (Red)	Switch+
Pin4 (Green)	Solenoid+
Pin5 (Yellow)	Not connected
Pin6 (Blue)	Switch-
CONTROL COMMAND	
ESC/ POS	Ready
OLE POS (OPOS) OCX	Ready
SUPPORTING OS	
DOS, UCDDOS, LINUX, Windows 95,98, NT,2000, ME, XP, XPe, Vista, Win7, Win8, Android, iOS	Ready

USB TRIGGER

The Cash Drawer Trigger is designed to provide USB interfacing to the cash drawer. This allows the cash drawer, which was previously connected to a POS printer or cash register, to be directly connected to a computer's USB port. This means, through the USB Trigger, the cash drawer can be connected directly to a computer when there is no receipt printer used in the POS system.

The USB Trigger Module uses a Virtual Serial Port Driver, making it appear to the software as if it's a standard RS232 Serial Port. This way the existing POS Software can communicate with the USB Cash Drawer Trigger as though connect to a Serial Port. A unique serial number is assigned to each USB Trigger Module and the Driver Software will assign the next available Serial Port to each device it recognizes (multiple Triggers can be used on one PC).

User may need to install the "virtual com" driver manually, which can be found in Royal website:

*www.royal.com in section *Support/Drivers and Manuals*.*

NOTE: Windows 7/8/10 are able to search driver from windows update.

The cash drawer can be connected directly to a computer with a USB Trigger powered by the USB bus. External power is not required.

Allows for "Hot Plugging" and Plug and Play connectivity.

WARRANTY, REGISTRATION & TECHNICAL SUPPORT

PLEASE FILL OUT AND RETURN THE PRODUCT REGISTRATION CARD INCLUDED WITH YOUR NEW ROYAL PRODUCT OR FILL OUT THE PRODUCT REGISTRATION FORM ON THE ROYAL WEB PAGE AT: [http:// www.royal.com](http://www.royal.com).

BE SURE TO KEEP A COPY OF YOUR SALES RECEIPT!

STANDARD WARRANTY

ROYAL CONSUMER INFORMATION PRODUCTS, INC. ("Royal"), at 1160 U.S. Highway 22 East, Suite 301 Bridgewater, NJ 08807 USA WARRANTS that your NEW Product is free of defects of workmanship and materials. If there is a defect or malfunction of this product, Royal will repair it free of charge as follows:

PARTS: New or comparable rebuilt parts in exchange for defective parts for ONE (1) YEAR from date of customer purchase.

LABOR: Royal provides labor warranty for ONE (1) YEAR from date of end-user purchase. Product must be sent postage prepaid and insured to Royal in accordance with the warranty procedures outlined below. At completion of the repair, the consumer will be responsible for return shipping charges from Royal, and for any parts or services no longer covered under warranty.

This warranty does not apply to persons who purchased this product second-hand or used.

This warranty does not include adjustments, parts and/or repairs required by circumstances beyond the control of Royal, including but not limited to fire or other casualty, accident, neglect, abuse, misuse, abnormal use or battery leakage damages.

THERE ARE NO OTHER EXPRESSED WARRANTIES EXCEPT AS STATED HEREIN. AFTER THE PERIOD OF EXPRESSED WARRANTY SET FORTH HEREIN, THERE ARE NO EXPRESSED OR IMPLIED WARRANTIES AND THOSE EXCLUDED INCLUDE THOSE OF MERCHANTABILITY AND FITNESS FOR PARTICULAR PURPOSE. Royal shall NOT be held liable for CONSEQUENTIAL DAMAGES resulting from any failure, defect or malfunction of this product. Some States do not allow limitations on how long an implied warranty lasts and some States do not allow the exclusion or limitation of incidental or consequential damages, so the above limitations may not apply to you.

WARRANTY PROCEDURES

TO OBTAIN SERVICE UNDER THE TERMS OF THIS WARRANTY:

Please do the following:

1. Send a copy of your original sales receipt showing original purchase date along with your mailing address and a note describing the nature of the problem to:

Royal Consumer Information Products, Inc.
Warranty Processing
50 Hilton Street
Easton, PA 18042-7391 USA

Do Not Return the Product to This Address!

2. You will receive a return authorization number within 7-12 business days from the date your return request is received if it is determined that there is a basis for a replacement product. The return authorization form you receive will list the return procedures, applicable charges, if any, and the correct shipping address for the returned product.

State of California Proposition 65 Warning

The following statement is required by the State of California.

Warning: This product may contain chemicals known to the State of California to cause cancer, birth defects, or other reproductive harm. Wash hands after handling

Cash Drawer
MB-30

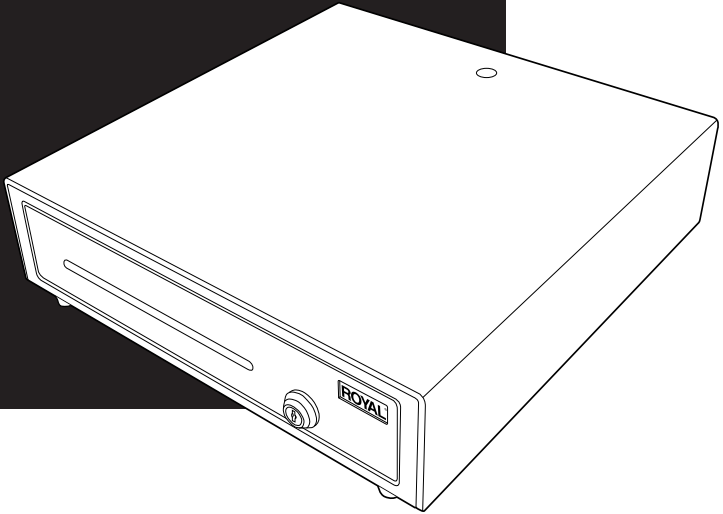

ROYAL Consumer Information Products

Product Registration Information

MB-30

Register Your Product online at:
www.royal.com

Date of Purchase: _____ Model: _____

Place of Purchase: _____

Lot / Serial Number: _____

Customer Support: 1-800-272-6229 {US}
1-888-266-9380 {Canada}
01-800-849-4826 {Mexico}

PLEASE KEEP THIS INFORMATION FOR YOUR RECORDS.

Cash Drawer **MB-30**

ROYAL[®]

Consumer Information Products, Inc.

1160 U.S. Highway 22 East
Suite 301
Bridgewater, NJ 08807

Made in China

© Copyright
Royal Consumer Information Products, Inc.
2018, All Rights Reserved.